

FABRICATION OF GD CONTAINING DUPLEX STAINLESS STEEL SHEET FOR NEUTRON ABSORBING STRUCTURAL MATERIALS

YONG CHOI¹, BYUNG M. MOON², and DONG-SEONG SOHN^{3*}

¹Department of Materials Science and Engineering, Dankook University, Cheonan, Chungnam 330-714, Korea

²Liquid Processing & Casting Technology R&D Group, KITECH, Incheon, 406-840, Korea

³Nuclear Science and Engineering Track, UNIST, Ulsan, 689-798, Korea

*Corresponding author. E-mail : dssohn@unist.ac.kr

Received February 19, 2013

Accepted for Publication May 08, 2013

A duplex stainless steel sheet with 1 wt.% gadolinium was fabricated for a neutron absorbing material with high strength, excellent corrosion resistance, and low cost as well as high neutron absorption capability. The microstructure of the as-cast specimen has typical duplex phases including 31% ferrite and 69% austenite. Main alloy elements like chromium (Cr), nickel (Ni), and gadolinium (Gd) are relatively uniformly distributed in the matrix. Gadolinium rich precipitates were present in the grains and at the grain boundaries. The solution treatment at 1070 °C for 50 minutes followed by the hot-rolling above 950 °C after keeping the sheet at 1200 °C for 1.5 hours are important points of the optimum condition to produce a 6 mm-thick plate without cracking.

KEYWORDS : Neutron Absorbing Material, Gd-duplex Stainless Steels, Casting

1. INTRODUCTION

Development of neutron absorbing structural materials for use in the storage and the transportation of spent nuclear fuels and high level wastes have been one of the hot issues in metallurgy and nuclear engineering area as the amount of spent nuclear fuel and high level nuclear wastes has been continuously increasing in the world [1]. Since neutron absorbing structural materials are generally used to store and transport spent nuclear fuel for a relatively long time under neutron and gamma radiation environment in dry or wet conditions, excellent corrosion resistance and good mechanical properties are required. Neutron absorbing structural materials are generally used in sheet shape in spent fuel storage racks.

Most of the spent fuel storage racks and spent fuel and high level waste transportation casks contain boron (B) as a neutron absorber. B has been widely used as a neutron absorber in reactor cores, in spent fuel racks, and in spent fuel and high level waste transportation casks. Recently gadolinium (Gd), which has a much higher neutron absorption cross section (49,163 vs. 745 barn, considering isotopic abundances in each element) and does not generate helium by the absorption of neutrons, has been introduced and used widely as a neutron absorber material in different nuclear fuels as an integrated burnable absorber. Conventional spent

fuel storage racks, as shown in Figure 1, have boron as a neutron absorbing material in aluminum sheets and these Al sheets are welded to stainless steel walls. In other cases, boron containing stainless steels are used as a neutron absorbing structural material.

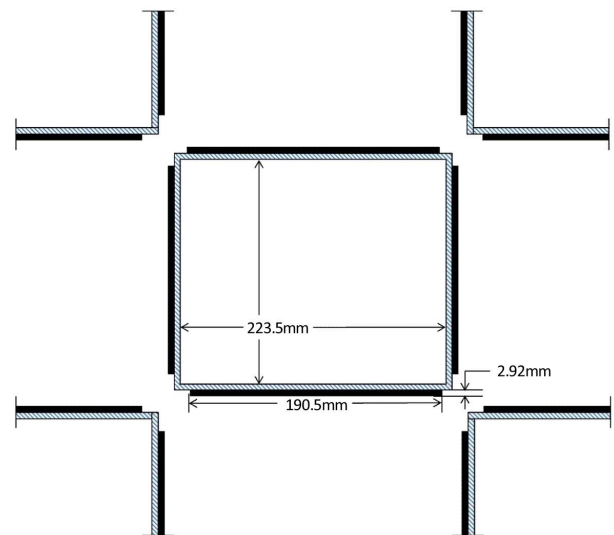

Fig. 1. Cross Section of a Typical Example of PWR Spent Fuel Storage Cells.

Several neutron absorbing structural materials with boron and gadolinium, such as aluminum-boron carbide cermets, boron aluminum alloys, boron stainless steel, and Ni-Cr-Mo-Gd alloys, have been developed and some of them were used in spent fuel storage racks and in spent fuel transportation casks[2-4].The boron aluminum alloy has a relatively lower melting point and lower mechanical strengths than other materials like stainless steels. Since only limited quantities of boron can be dissolved in aluminum, boron forms boron-rich borides as precipitates at the grain boundaries of the aluminum alloy matrix [5]. Aluminum-boron carbide cermets can be produced by a relatively expensive process. It is difficult to make a homogeneous microstructure and obtain maximum theoretical density because of a physical mixture of ceramics and metals [6]. Boron-stainless steel represents the neutron absorber material with durability and high corrosion resistance. However, the solubility of boron in stainless steel is low and the production of alloys with more than 2.25 wt.% is difficult [7].Recently a Ni based Gd alloy was developed for neutron absorption applications where up to 2.1 wt.% Gd is dispersed in a Ni-Cr-Mo base alloy [8]. It is registered in ASTM B932-04 [9] and was approved for use in the non-welded condition.

Since gadolinium has higher thermal neutron absorption cross section than boron, it makes a more effective element addition for neutron absorption. Ni-Cr-Mo-Gd alloy has extremely limited solubility in the nickel austenitic matrix. Precipitate Ni₅Gd gadolinide at grain boundaries makes it difficult to produce sheet form by mechanical rolling. Furthermore, gadolinium in the alloy does not dissolve as quickly as chromium borides in the presence of water when the material corrodes [10]. Accordingly, gadolinium-stainless steel with high strength and high corrosion resistance is a useful neutron absorber material from a metallurgical and nuclear engineering point of view [11].

Among various stainless steels, duplex stainless steels of ferrite and austenite have an excellent combination of resistance to corrosion and stress corrosion cracking, and high strength and low cost due to reduced contents of Ni and Mo[12]. The manufacturing problems to make a sheet are the precipitation of detrimental phases such as σ -phase and M₂₃C₆, the low hot ductility, and edge crack formation. The σ -phase of the duplex stainless steels is precipitated during high temperature processes like casting and welding. It is difficult to prevent the precipitation of the σ -phase when the Cr content exceeds 20wt.% in stainless steels. The addition of a strong ferrite stabilizer (Cr, Si, Mo) into the stainless steels leads to the formation of the σ -phase. The σ -phase is consumed completely by the $\sigma+\gamma_2$ cellular structures after aging at 1100 °C for 0.5 hours and at 800 °C for 10 hours [13]. It means that a precise control of alloying elements and processing parameters can retard the formation of detrimental precipitates. Hence the objectives of this study are to design a Gd containing duplex stainless steel and optimize the processing conditions to make a sheet for neutron absorbing structural material application.

2. EXPERIMENTAL METHOD

2.1 Design of a Gd-duplex Stainless Steel

Gd content of the duplex S.S. was designed to have a higher neutron absorption cross section than currently available neutron absorbing structural materials. The boron content of practical borated stainless steel (for example, A887 B6[3]), currently adopted for spent fuel rack fabrication, is designed to have less than 1.75% of boron. Natural boron has two neutron absorbing isotopes, B-10 and B-11, as listed in Table 1. B-10, whose natural abundance is about 20% and absorption cross section is 3,840 barns, is

Table 1. Main Characteristics of B and Gd as Neutron Absorbers

Element	Isotopes	Relative abundance, (wt. %)	Neutron absorption cross section (CX), barns	Density [g/cm ³]	Effective CX
Boron	B-10	19.9	3,840	2.46	745
	B-11	80.1	0.005		
Gadolinium	Gd-152	0.20	1,400	7.41	49,163
	Gd-154	2.18	290		
	Gd-155	14.80	62,540		
	Gd-156	20.47	12		
	Gd-157	15.65	255,000		
	Gd-158	24.84	7		
	Gd-160	21.86	1.8		

the much stronger absorber. Gadolinium has 7 neutron absorbing isotopes and 3-4 isotopes are major contributors for neutron absorption. Gd-157 has the highest absorption cross section of 255,000 barns. Relative abundances of different isotopes should be considered together with their absorption cross section to calculate the effective cross section of each element. The required Gd content which gives the same neutron absorption as 1.75 % borated SS is calculated to be 0.445 %. A high Gd content in matrix for neutron absorption increases brittleness of the materials and resultantly retards plastic formability to make a sheet. In this study, the target Gd content in Gd containing duplex SS was set to be 1.0 % considering the possibility to reduce the wall thickness of the spent fuel storage rack so that it is possible to store more spent fuel in a given space and to produce a sheet without cracking during the rolling process. Although MCNP code calculation with the exact geometry data is needed for exact calculation of the equivalent Gd concentration for an existing spent fuel rack with borated stainless steel, this basic calculation without using any computer code could give meaningful results for comparison of equivalent Gd concentration to 1.75 % borated stainless steel.

2.2 Melting and Casting

Engineering grade pure iron (>99.99), chromium (>99.99), nickel (>99.99), manganese (>99.99), and silicon (>99.99) were used. Mother alloys like iron-molybdenum, iron-gadolinium and, iron-chromium-nitrogen were prepared by vacuum arc melting (PAM-Plasma, Japan) to meet the final composition of the aimed alloy. In this study, a duplex stainless steel was designed to have the ratio of 3-ferrite to 7-austenite to enhance ductility for hot-rolling. Table 1 is the aim composition and the final composition after melting, determined by X-ray photoelectron spectroscopy (Jeol JPS-9200, Japan).

A melting process to produce the duplex stainless steel with gadolinium was carried out with a high-frequency induction melting furnace (Inductotherm, USA) in which inert argon gas was purged on the top of an alumina crucible installed with the mother alloys and pure metals to prevent oxidation. The melt was poured into a Y-block metal mold

to make a sheet shape. Fig. 2 is the schematic diagram of the Y-block metal mold. Total melting time during induction heating, the maximum melting temperature, and pouring temperature were 0.5 hr, 1680 °C, and 1640 °C, respectively. Table 2 is the amount of charge materials per lot after considering a final yielding.

2.3 Rolling and Solution Treatment

The casting poured into the Y-block mold was mechanically sectioned from gating and risering parts before being hot-rolled. The hot-rolling (M-tech, Korea) was performed three times under forward feeding condition above 950 °C after keeping the sheet at 1200 °C for 1.5 hours. The minimum hot rolling temperature of 950 °C was chosen to prevent cracks due to s-phase during hot-rolling. The initial and final dimensions of the hot-rolled casting were L-150 x W-75 x T-15 and L-350 x W-90 x T-6mm, respectively. The hot-rolled sheet was rapid-heated at 13 °C/min for a solution treatment at 1070 °C for 50 minutes to remove intermetallic compounds like σ - and χ -phases, which make cracks during cooling to room temperature. Finally, it was water-quenched. Fig. 3 is a schematic diagram of the heat treatment history.

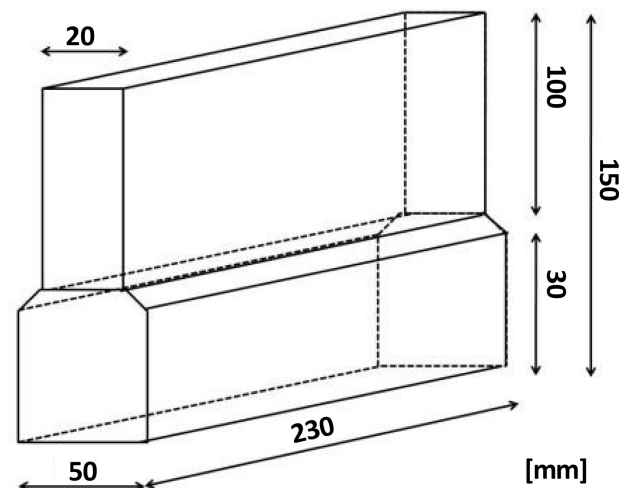

Fig. 2. Schematic Diagram of the Y-block Metal Mold.

Table 2. Composition of Specimen [wt.%]

	Fe	Cr	Ni	Mo	N	C	Si	Mn	Gd
Aimed	Bal.	22	5	3	<0.1	<0.02	0.5	0.8	1
Analyzed	68.170	21.929	5.240	3.295	0.048	0.011	0.416	0.600	1.020

Table 3. Charged Materials for Melting Per a Lot [kg]

Materials	Fe	Cr	Ni	Mn	Si	Fe-Mo	Fe-Gd(4:6)	Fe-Cr-N	total
Weight	5.8608	2.004	0.468	0.0816	0.035	0.491	0.3048	0.12	9.3652

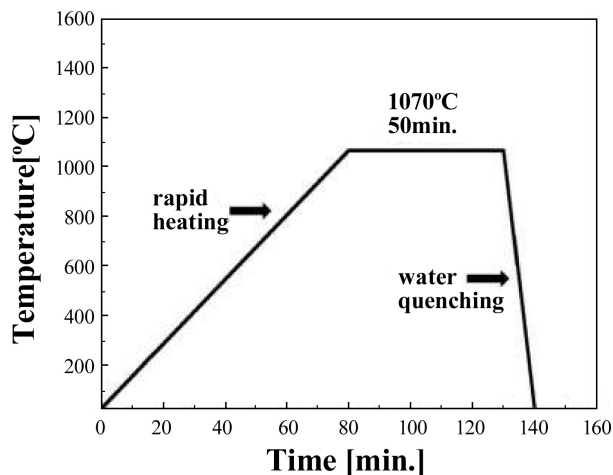

Fig. 3. Schematic Diagram of a Heat Treatment History.

2.4 Microstructure Observation and Chemical Analysis

Microstructure was observed by optical microscopy (Nikon EPIPHOT-200, USA) after polishing and etching with a modified Murakami’s solution ($K_3Fe(CN)_6 : KOH : H_2O = 1 : 1 : 5$). Chemical analysis of the hot-rolled Gd-duplex stainless steels was carried out by scanning electron microscopy (Jeol, JSM 6400, Japan) and energy dispersive spectroscopy (Oxford, UK), respectively.

2.5 Mechanical Tests

Mechanical properties of the materials were determined by a universal test machine (Shimazu AG-1, Japan) according to ASTM E-8. The specimen was spark-machined and polished with emery papers.

3. RESULTS AND DISCUSSION

Fig. 4 is a photo of a hot-rolled specimen, the dimensions of which are L-350xW-90xT-6 mm. The hot-rolling process made a plan sheet without thermal distortion and edge-cracks. It means that the hot-rolling and heat treatment conditions used in this study are suitable for the production of a stainless steel sheet. Mechanical properties of the hot-rolled Gd-duplex stainless steel were 700.2 MPa of ultimate tensile strength, 552.3 MPa of yield strength, and 38.08% of elongation.

Fig. 5 shows the optical microscopic (OM) images of the hot-rolled specimen. The microstructure of the hot-rolled specimen is typical of duplex stainless steels including ferrite and austenite phases. Since a minimal solubility of gadolinium in stainless steel exists, gadolinium rich phases precipitate inter-dendritic region. The coarse two-phase structures of ferrite and austenite phases were observed inside of the grain or on the grain boundary. Ferrite oscilloscope revealed that the amounts of ferrite and austenite



Fig. 4. Photo of a Hot-rolled Specimen L-350xW-90xT-6 [mm]

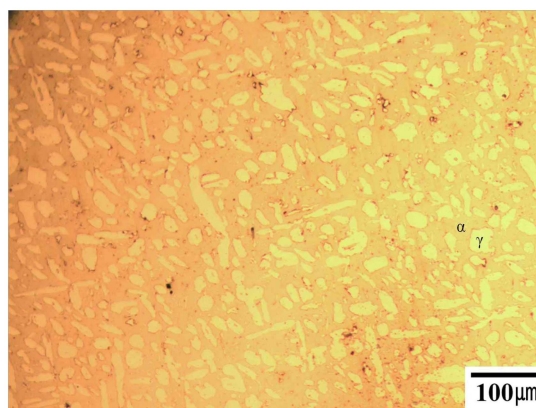

Fig. 5. Optical Microscopic (OM) Image of a Hot-rolled Specimen.

were 31% and 69%, respectively. It is interesting why the two phases have a unique morphology. Since the austenite phase is more stable at low temperatures than the ferrite phase in the Fe-Cr phase diagram, the austenite precipitates through a nucleation and growth process on the grain boundary and inside the grain as a grain boundary. Accordingly, austenite allotriomorphs are formed first at the ferrite grain boundaries, from which Widmanstätten austenite needles extend inside the ferrite grains. Large arrays of parallel austenite needles are also observed due to the heterogeneous nucleation and growth process.

Chemical analysis was carried out to confirm the Gd distribution by energy dispersive spectroscopy (EDX). Fig. 6 is a scanning electron microscopic (SEM) image and EDX spectra of the as-cast specimen. As shown in Fig. 5, the SEM image shows equi-axed grains with precipitates at the grain boundary and inside grains on the surface of the sample normal direction. Chemical mappings on a large scale also show that main alloy elements like chromium (Cr), nickel (Ni), and gadolinium (Gd) are relatively uniformly distributed in the matrix. A part of the gadolinium was partially segregated inside grains and at the grain boundary. It means that the gadolinium-rich precipitates are present in the duplex stainless steels.

In order to confirm the phase of large precipitates, chemical analysis of the precipitate was performed. Fig. 7 and 8 are SEM images and EDX spectra of the precipitates at the

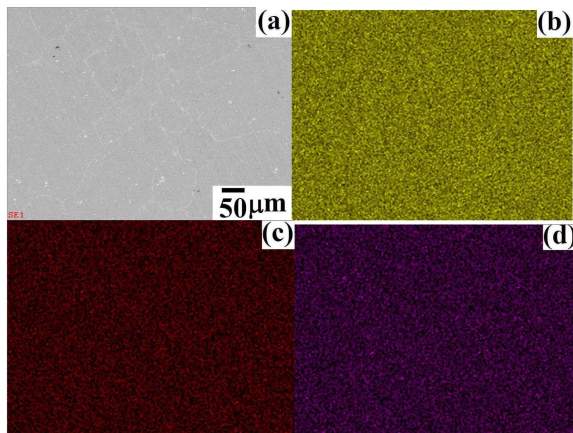

Fig. 6. Scanning Electron Microscopic Image and EDX Spectra of Gd-duplex Stainless Steels.: (a) SEM Image (b) Cr (c) Ni (d) Gd

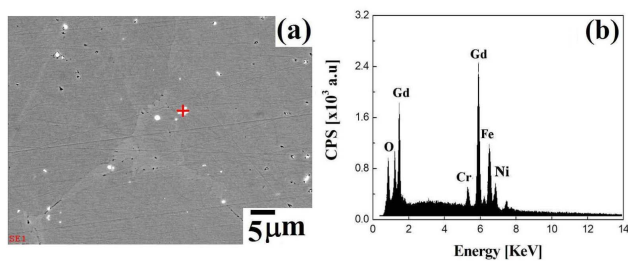

Fig. 7. SEM Image and EDX Spectra of the Precipitates Inside Grain of as-cast Specimen.

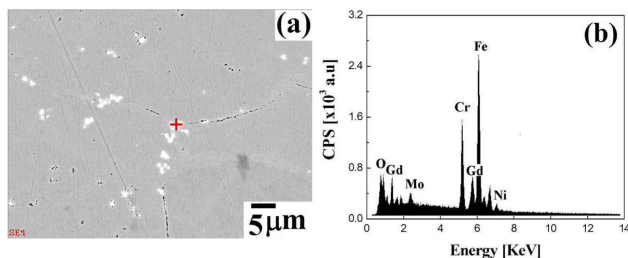

Fig. 8. SEM Image and EDX Spectra of the Precipitates at the Grain Boundary of as-cast Specimen.

grain boundary and inside the grain of the as-cast specimen. As shown in Fig. 7, EDX compositional analysis shows that the precipitate inside the grain has the composition of Fe : Cr : Ni : Mo : Gd : O = 50.07 : 18.77 : 3.22 : 1.63 : 8.52 : 17.79 [at.%]. As shown in Fig. 8, EDX compositional analysis of the precipitate at the grain boundary shows that it has the composition of Fe : Cr : Ni : Mo : Gd : O = 24.36 : 11.29 : 1.36 : 3.10 : 30.58 : 29.31 [at.%]. Although quantitative analysis of EDX makes it hard to predict the precise composition of a phase, it is clear that the precipitate inside of a grain has more gadolinium than that at the grain boundary. When gadolinium exists greater than the solubility limit of a duplex stainless steel, several types of gadolinium

compounds in matrix may be present like elemental Gd, GdO_2 , Gd_2O_3 , Gd_2Fe , $GdCrO_3$, $GdMo_5O_6$, etc. Comparing the compositional analysis of the precipitates inside of grains and at the grain boundary, the gadolinium rich phases could be gadolinium oxides with slightly different compositions. The reason why the precipitate in the matrix has more gadolinium content is due to the distribution of oxygen and comparative formation of other phases like chromium carbide at the grain boundary.

4. SUMMARY

In order to develop a new alloy with higher neutron absorption capability than borated stainless steels, excellent resistance to corrosion and stress corrosion cracking, high strength, adequate formability, and low cost, a new Gd containing duplex stainless steel was designed to have 1 wt. % Gd. The alloy sheet was produced by melting, casting, and hot-rolling with solution treatment. The microstructure of the as-cast specimen is typical of duplex stainless steels including 31% ferrite and 69% austenite phases. Main alloy elements like chromium (Cr), nickel (Ni), and gadolinium (Gd) are relatively uniformly distributed in the matrix. Gd rich precipitates were present inside the grains and at the grain boundaries. The hot-rolling above 950°C, keeping the sheet at 1200 °C for 1.5 hours after a solution treatment at 1070°C for 50 minutes, produced a 6 mm-thick plate without cracking. Ultimate tensile strength, yield strength, and elongation of the hot-rolled Gd-duplex stainless steel were 700.2 MPa, 552.3 MPa, and 38.08%, respectively.

ACKNOWLEDGEMENTS

One of authors thanks that this work was supported by the UNIST (Ulsan National Institute of Science and Technology) Research Fund (No. 2010-1.100044.01) and by the National Research Foundation of Korea (NRF) grant funded by the Korean government (Ministry of Education, Science and Technology) (No. 2011-0031771)

REFERENCES

- [1] A. Machiels and R. Lambert, "Handbook on Neutron Absorber Materials for Spent Nuclear Fuel Applications", 2005-ed. 1011818, Electronic Power Research Institute (2005).
- [2] ASTM C750-89, "Standard Specifications for Nuclear Grade Boron Carbide Powder", (1997).
- [3] ASTM A 887-89, "Standard Specification for Borated Stainless Steel Plate, Sheet, and Strip for Nuclear Application", (2004)
- [4] J. Shimojo, H. Taniuchi, K. Kajihara and Y. Aruga, "Borated Aluminum Alloy Manufacturing Technology", *Kobe Steel Engineering Reports*, **53**(3), 12 (2003).
- [5] P. Moldovan and G. Popescu, "The Grain Refinement of 6063 Aluminum Using Al-5Ti-1B and Al-3Ti - 0.15 C Grain Refiners", *J. of Metals*, **56**(11), 59 (2004).
- [6] D. C. Halverson, A. J. Pyzik and I. A. Aksay, "Processing

- of Boron Carbide-Aluminum Composites” *J. of American Ceramic Society*, **72**(5), 7759 (1989).
- [7] L. Karisson and H. Norden, “Non-equilibrium Grain Boundary Segregation of Boron in Austenitic Stainless Steel-II. Fine Scale Segregation Behavior”, *Acta Metallurgica*, **36**(1), 13 (1988).
- [8] G.W. Wachs, J.W. Sterbentz, et al., “Nickel Based Gadolinium Alloy for Neutron Adsorption Application in Ram Package”, PATRAM 2007, Miami, Florida, Oct. 2007
- [9] ASTM B932-04, “Standard Specifications for Low-Carbon Nickel-Chromium-Molybdenum-Gadolinium Alloy Plate, Sheet, and Strip” (2004)
- [10] G. W. Wachs, J. W. Sterbentz, L. M. Montierth, F. K. Tovesson and T. S. Hill, “Characterization of an Advanced Gadolinium Neutron Absorber Alloy by Means of Neutron Transmission”, INL/CON-07-12838, Idaho National Laboratory (2007).
- [11] Z. Khan, “Influence of Gadolinium on the Microstructure and Mechanical Properties of Steel and Stainless Steel”, *J. Southern African Institute of Mining and Metallurgy*, **112**, 309 (2003).
- [12] K. Ravindranath and S. N. Malhotra, “The influence of Aging on the Intergranular Corrosion of 22 Chromium-5 Nickel Duplex Stainless Steel”, *Corrosion Science*, **37**(1), 121 (1995).
- [13] X. Tang, “Sigma Phase Characterization in AISI 316 Stainless Steel,” *Microscopy and Microanalysis*, **11**(2), 78 (2005).